

# TYPE 400

# 3-WAY BRASS BALL VALVE

Screwed body cap, 2-seat, L-port design,  
Blowout-proof Stem, Double O-ring stem seals\*  
Threaded ends to BS21 or NPT, or solder joint ends.

W.O.G. non-shock 2.76 MPa (400 psi), W.O.G. 150°C 0.69 MPa (100 psi)

\*Size 1/2 and larger



**Fig. TN**

• Threaded end to BS21

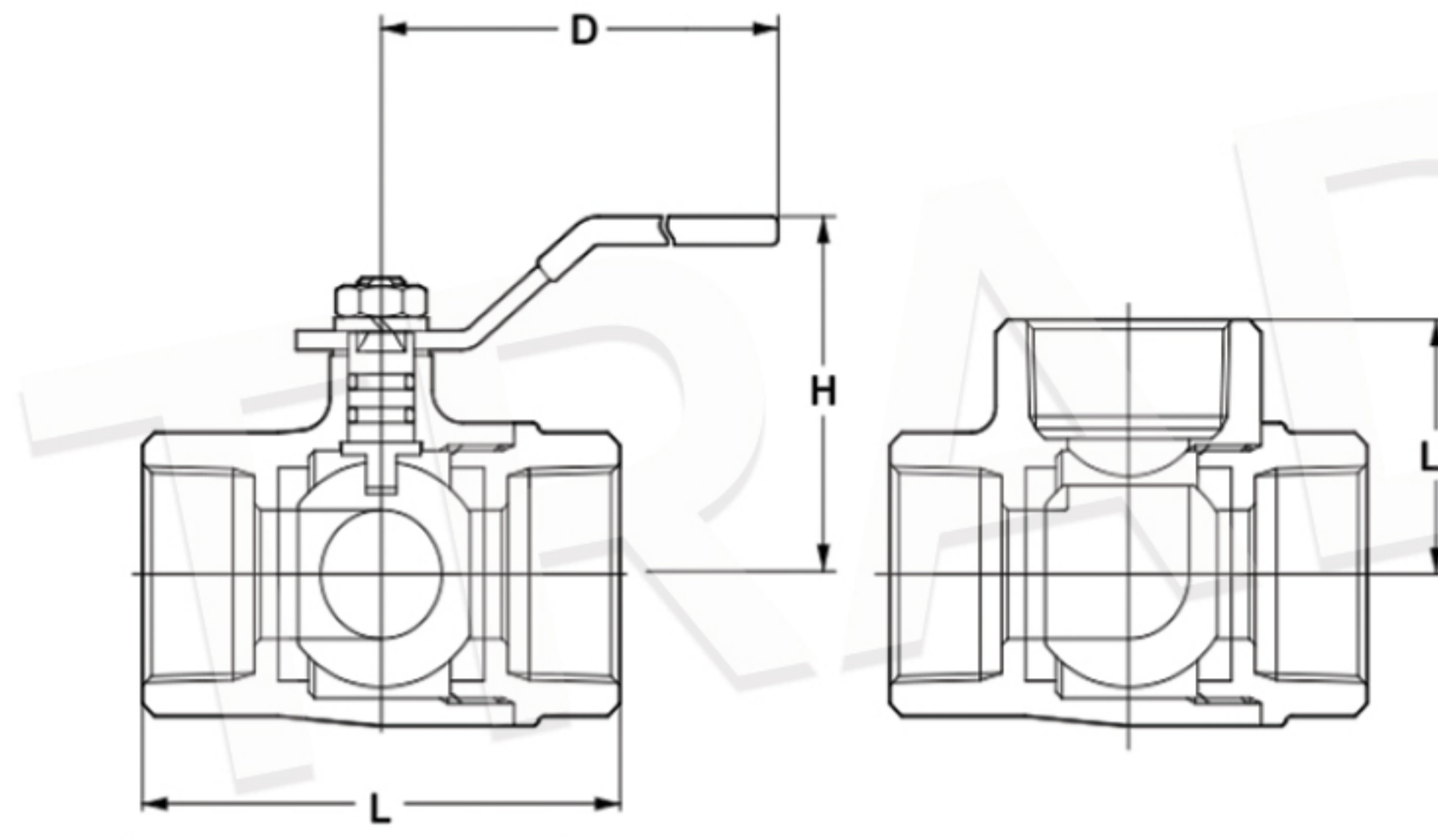

### Materials

\*Size 2 1/2 and 3

Parts	Material
Body	Brass/Bronze*
Body cap	Brass
Stem	Dezincification Resistant Brass
Ball	Brass**
Ball seat	PTFE
O-ring	FKM

\*\*Chrome or Nickel-chrome plated



Solder joint end valves should not be used in service where the temperature of line fluid is higher than the softening point of solder.

### Dimensions (TN/AKTN)

Nominal Size	mm										
	inch	1/4	3/8	1/2	3/4	1	1 1/4	1 1/2	2	2 1/2	3
	mm	8	10	15	20	25	32	40	50	65	80
<b>L</b>		40	46	67	68	79	89	100	115	138	166
<b>L1</b>		20	23	33.5	34	39.5	44.5	50	57.5	69	83
<b>H</b>		30	35	45	48	55	60	65	75	91	105
<b>D</b>		60	70	80	80	110	110	110	140	200	300

Port position fig: Position 1 & 2